

FIG.293 SELF RECOVERY WINCH ASSEMBLY (SHEET 2 OF 2)

SECTION II			TM 9-2320-279-24P			
(1)	(2)	(3)	(4)	(5)	(6)	
ITEM	SMR		PART			
NO	CODE	CAGEC	NUMBER	DESCRIPTION AND USABLE ON CODES(UOC)	QTY	
				GROUP 2001 HOIST, CAPSTAN, WINDLASS, CRANE OR WINCH ASSEMBLY FIG.293 SELF RECOVERY WINCH ASSEMBLY		
1	PAOHH	0EJ14	50850	WINCH,DRUM,VEHICLE	1	
				UOC:H01,H02,H03,H04,H05,H40,H41		
2	PFHZZ	0EJ14	11311	.SUPPORT,GEAR END	1	
				UOC:H01,H02,H03,H04,H05,H40,H41		
3	PAHZZ	0EJ14	9965	.PACKING,PREFORMED	2	
				UOC:H01,H02,H03,H04,H05,H40,H41		
4	PAHZZ	0EJ14	9928	.SEAL,PLAIN	2	
				UOC:H01,H02,H03,H04,H05,H40,H41		
5	PFHZZ	0EJ14	11318	.BEARING,SLEEVE	2	
				UOC:H01,H02,H03,H04,H05,H40,H41		
6	PFHZZ	0EJ14	11358	.HUB,DRUM,WINCH	1	
				UOC:H01,H02,H03,H04,H05,H40,H41		
7	PAHZZ	58864	9835	.PACKING,PREFORMED	2	
				UOC:H01,H02,H03,H04,H05,H40,H41		
8	PFHZZ	0EJ14	11357	.GEAR,INTERNAL	1	
				UOC:H01,H02,H03,H04,H05,H40,H41		
9	PFHZZ	0EJ14	3123	.CARRIER ASSEMBLY,SE	1	
				UOC:H01,H02,H03,H04,H05,H40,H41		
10	PAHZZ	96906	MS16562-272	.PIN,SPRING	4	
				UOC:H01,H02,H03,H04,H05,H40,H41		
11	PAHZZ	0EJ14	1495	.WASHER,LOCK	24	
				UOC:H01,H02,H03,H04,H05,H40,H41		
12	XAHZZ	80204	B1821BH050C200N	.SCREW,CAP,HEXAGON H	12	
				UOC:H01,H02,H03,H04,H05,H40,H41		
13	PAHZZ	0EJ14	11322	.PLATE,RETAINING,SHA	1	
				UOC:H01,H02,H03,H04,H05,H40,H41		
14	PFHZZ	0EJ14	3152	.GEAR,SPUR	1	
				UOC:H01,H02,H03,H04,H05,H40,H41		
15	PAHZZ	0EJ14	3153	.RING,RETAINING	1	
				UOC:H01,H02,H03,H04,H05,H40,H41		
16	PFHZZ	0EJ14	3124	.CARRIER ASSEMBLY,WI	1	
				UOC:H01,H02,H03,H04,H05,H40,H41		
17	PFHZZ	0EJ14	11316	.GEAR,SPUR	1	
				UOC:H01,H02,H03,H04,H05,H40,H41		
18	PFHZZ	0EJ14	11359	.HUB,DRUM,WINCH	1	
				UOC:H01,H02,H03,H04,H05,H40,H41		
19	PAHZZ	0EJ14	1409	.SCREW,CAP,HEXAGON H	12	
				UOC:H01,H02,H03,H04,H05,H40,H41		
20	PAOZZ	0EJ14	1987	.PLUG,PIPE	2	
				UOC:H01,H02,H03,H04,H05,H40,H41		
21	PFHZZ	58864	11310	.SUPPORT,MOTOR END	1	
				UOC:H01,H02,H03,H04,H05,H40,H41		
22	PAOZZ	57733	47200	.VALVE,SAFETY RELIEF	1	
				UOC:H01,H02,H03,H04,H05,H40,H41		
23	PAOZZ	58864	11319	.ROPE,WIRE	1	
				UOC:H01,H02,H03,H04,H05,H40,H41		
24	PAOZZ	11083	1J5999	.SCREW,CAP,HEXAGON H	16	
				UOC:H01,H02,H03,H04,H05,H40,H41		

SECTION II			TM 9-2320-279-24P		
(1)	(2)	(3)	(4)	(5)	(6)
ITEM NO	SMR CODE	CAGEC	PART NUMBER	DESCRIPTION AND USABLE ON CODES(UOC)	QTY
25	PAOZZ	0EJ14	1495	.WASHER, LOCK UOC:H01,H02,H03,H04,H05,H40,H41	16
26	PFOZZ	0EJ14	11314	.BRACKET, MOUNTING UOC:H01,H02,H03,H04,H05,H40,H41	1
27	PAFZZ	0EJ14	11052	.COUPLING, SHAFT, RIGI UOC:H01,H02,H03,H04,H05,H40,H41	1
28	PAFZZ	96906	MS16562-147	.PIN, SPRING UOC:H01,H02,H03,H04,H05,H40,H41	1
29	PAFZZ	0EJ14	76144	.PLUG UOC:H01,H02,H03,H04,H05,H40,H41	2
30	PAFZZ	0EJ14	76511	.ELBOW, PIPE UOC:H01,H02,H03,H04,H05,H40,H41	2
31	PAFZZ	0EJ14	75025	.HOSE ASSEMBLY, NONME UOC:H01,H02,H03,H04,H05,H40,H41	1
32	PAFZZ	0EJ14	1345	.SCREW, CAP, SOCKET HE UOC:H01,H02,H03,H04,H05,H40,H41	3
33	PAFZZ	58864	1143	.SCREW UOC:H01,H02,H03,H04,H05,H40,H41	2
34	PAFZZ	0EJ14	1144	.WASHER, LOCK UOC:H01,H02,H03,H04,H05,H40,H41	2
35	PAFZZ	0EJ14	11262	.GASKET UOC:H01,H02,H03,H04,H05,H40,H41	1
36	PAFZZ	58864	1502	.SCREW, CAP, HEXAGON H UOC:H01,H02,H03,H04,H05,H40,H41	2
37	PAFZZ	0EJ14	1595	.WASHER, LOCK UOC:H01,H02,H03,H04,H05,H40,H41	2
38	PAFZZ	58864	76044	.PACKING, PREFORMED UOC:H01,H02,H03,H04,H05,H40,H41	1
39	PFOZZ	0EJ14	11315	.BRACKET, MOUNTING UOC:H01,H02,H03,H04,H05,H40,H41	1

END OF FIGURE

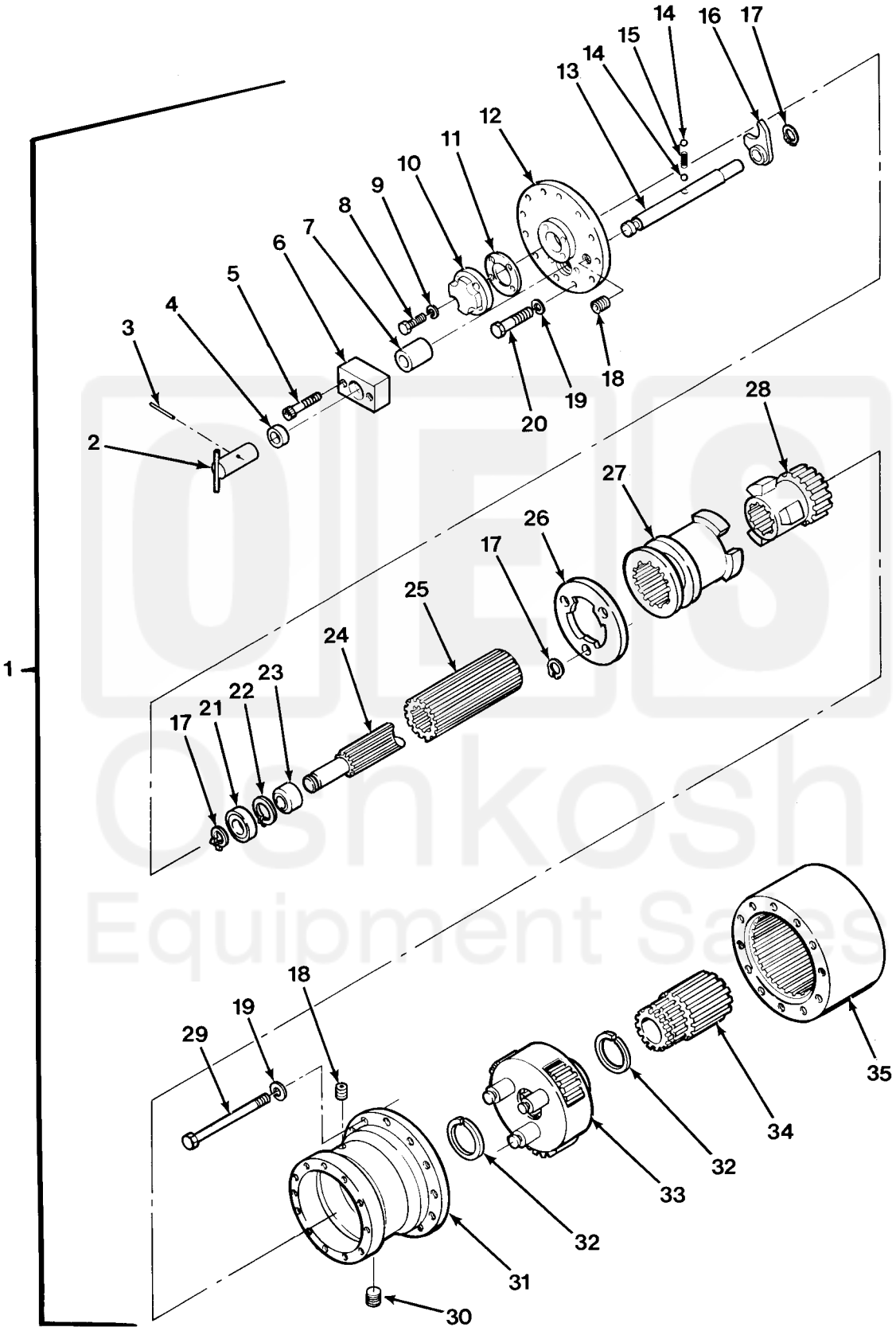

FIG. 303 HEAVY DUTY WINCH ASSEMBLY - M984 (SHEET 1 OF 3)

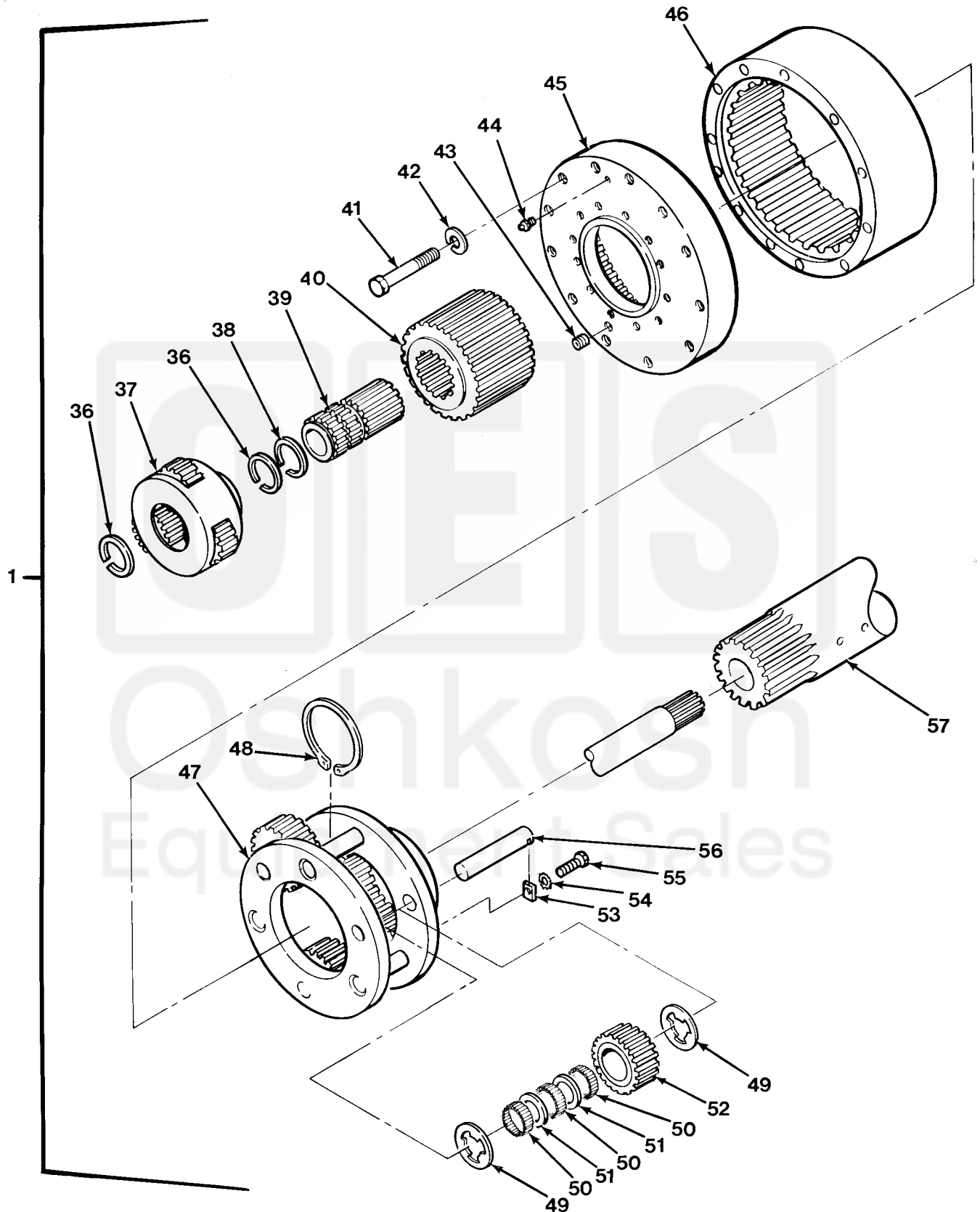

FIG.303 HEAVY DUTY WINCH ASSEMBLY - M984 (SHEET 2 OF 3)

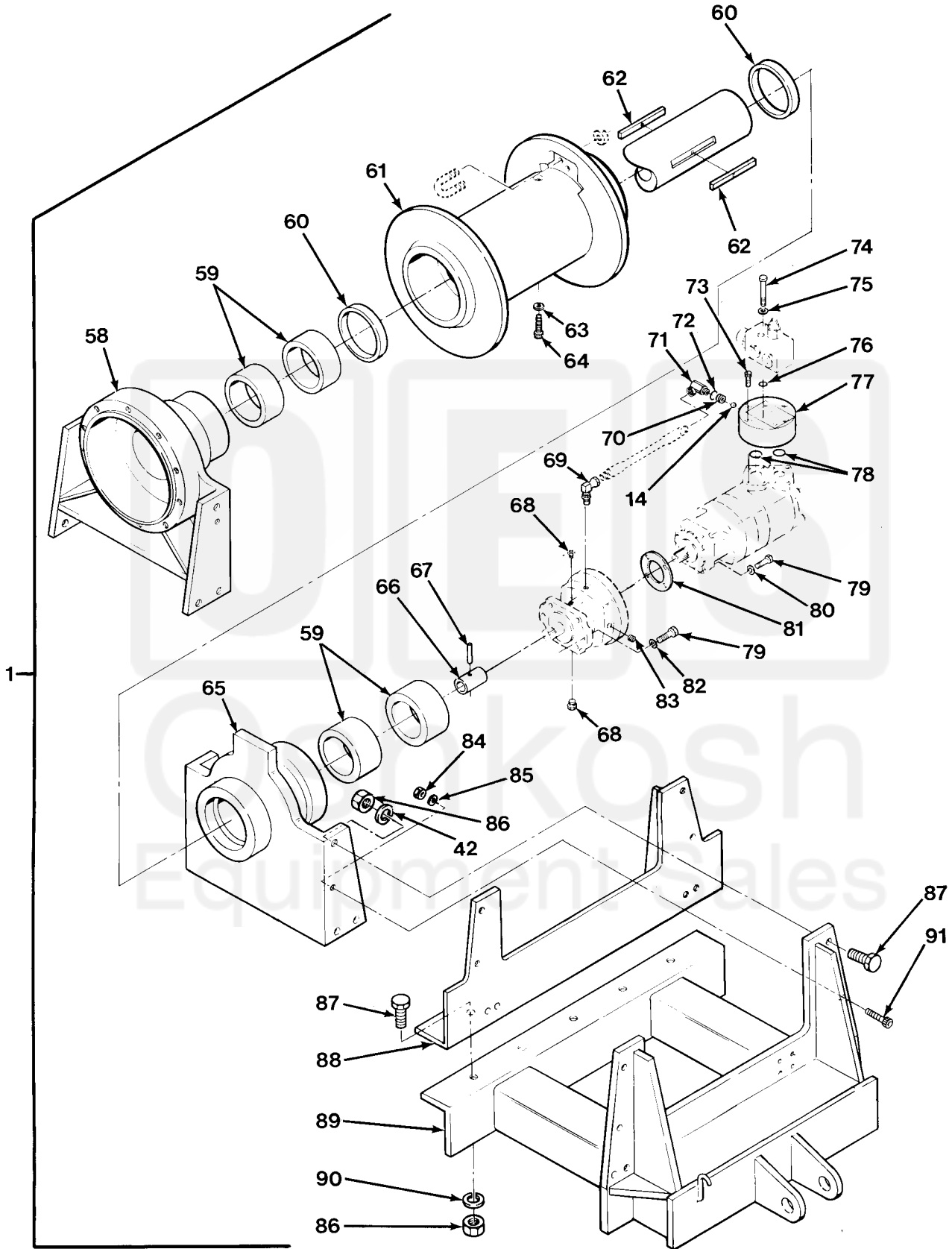

FIG.303 HEAVY DUTY WINCH ASSEMBLY - M984 (SHEET 3 OF 3)

SECTION II

TM 9-2320-279-24P

(1) ITEM NO	(2) SMR CODE	(3) CAGEC CAGEC	(4) PART NUMBER	(5) DESCRIPTION AND USABLE ON CODES(UOC)	(6) QTY
GROUP 2001 HOIST, CAPSTAN, WINDLASS, CRANE OR WINCH ASSEMBLY FIG.303 HEAVY DUTY WINCH ASSEMBLY - M984					
1	PAFHH	58864	50818	WINCH,DRUM,POWER OP UOC:H04	1
2	PAHZZ	58864	11373	.HANDLE,SHIFTER UOC:H04	1
3	PAHZZ	58864	3182	.PIN,SPRING UOC:H04	1
4	PAHZZ	58864	9809	.SEAL,PLAIN 1 INCH ID UOC:H04	1
5	PAHZZ	58864	1343	.SCREW,CAP,SOCKET HE UOC:H04	2
6	PFHZZ	58864	11159	.HOUSING,SHIFTER,WIN UOC:H04	1
7	PAHZZ	58864	11157	.BUSHING,SLEEVE UOC:H04	1
8	PAHZZ	58864	1166	.BOLT,MACHINE UOC:H04	4
9	PAHZZ	0EJ14	1168	.WASHER,LOCK UOC:H04	4
10	PFHZZ	58864	11105	.COVER,SMALL WINCH UOC:H04	1
11	PAHZZ	58864	9996	.GASKET UOC:H04	1
12	PFHZZ	58864	11202	.PLATE,RETAINING,SHA UOC:H04	1
13	PFHZZ	58864	11155	.SHAFT,SHOULDERED UOC:H04	1
14	PAHZZ	96906	MS19059-2414	.BALL,BEARING UOC:H04	3
15	PAHZZ	58864	2318	.SPRING,HELICAL,COMP UOC:H04	1
16	PFHZZ	58864	11158	.SHIFTER UOC:H04	1
17	PAHZZ	58864	3115	.RING,RETAINING UOC:H04	5
18	PAFZZ	58864	1988	.PLUG,PIPE UOC:H04	2
19	PAHZZ	0EJ14	1395	.WASHER,LOCK UOC:H04	22
20	PAHZZ	58864	303	.BOLT,MACHINE UOC:H04	10
21	PAHZZ	58864	81428	.BEARING,BALL,ANNULA UOC:H04	1
22	PAHZZ	58864	3109	.RING,RETAINING UOC:H04	1
23	PFHZZ	58864	11340-8	.SPACER,RING UOC:H04	1
24	PFHZZ	58864	11368	.SHAFT,SHOULDERED UOC:H04	1

SECTION II

TM 9-2320-279-24P

(1) ITEM NO	(2) SMR CODE	(3) CAGEC	(4) PART NUMBER	(5) DESCRIPTION AND USABLE ON CODES(UOC)	(6) QTY
25	XDHZZ	58864	11204	.GEAR, SPUR UOC:H04	1
26	PFHZZ	58864	11203	.PLATE, RETAINING, SHA UOC:H04	1
27	PFHZZ	0EJ14	11208	.HUB, BODY UOC:H04	1
28	PFHZZ	58864	11238	.GEAR, SPUR UOC:H04	1
29	PAHZZ	0EJ14	1317	.SCREW, CAP, HEXAGON H UOC:H04	12
30	XDFZZ	58864	3049	.PLUG, PIPE, MAGNETIC UOC:H04	1
31	PFHZZ	58864	11371	.HOUSING, MECHANICAL UOC:H04	1
32	PAHZZ	58864	3054	.RING, RETAINING UOC:H04	2
33	PFHZZ	58864	11356	.CARRIER ASSEMBLY, WI UOC:H04	1
34	PFHZZ	58864	11239	.GEAR CLUSTER UOC:H04	1
35	PFHZZ	58864	81120	.GEAR, RING UOC:H04	1
36	PAHZZ	0EJ14	3148	.RING, RETAINING 2PC UOC:H04	3
37	PFHZZ	58864	3139	.CARRIER, WINCH UOC:H04	1
38	PAHZZ	0EJ14	3041	.RING, RETAINING UOC:H04	1
39	PFHZZ	0EJ14	10757	.SHAFT, STRAIGHT UOC:H04	1
40	PFHZZ	0EJ14	10998	.GEAR, SPUR UOC:H04	1
41	PAHZZ	0EJ14	1618	.SCREW, CAP, HEXAGON H UOC:H04	12
42	PAHZZ	0EJ14	1695	.WASHER, LOCK UOC:H04	12
43	XDHZZ	90940	613126	.PLUG, PIPE, MAGNETIC UOC:H04	1
44	PAHZZ	58864	3059	.VALVE, SAFETY RELIEF UOC:H04	1
45	PFHZZ	0EJ14	10774	.COVER, ADAPTER WIN UOC:H04	1
46	PFHZZ	0EJ14	10997	.GEAR, RING UOC:H04	1
47	PFHZZ	0EJ14	10996	.CARRIER PLANETARY UOC:H04	1
48	PAHZZ	0EJ14	3060	.RING, RETAINING UOC:H04	1
49	PAHZZ	0EJ14	3028	.BEARING, WASHER, THRU UOC:H04	6
50	PAHZZ	0EJ14	81419	.BEARING, ROLLER, NEED UOC:H04	1

SECTION II

TM 9-2320-279-24P

(1) ITEM NO	(2) SMR CODE	(3) CAGEC	(4) PART NUMBER	(5) DESCRIPTION AND USABLE ON CODES(UOC)	(6) QTY
51	PAHZZ	0EJ14	10744	.RETAINER,ROLLER,BEA UOC:H04	6
52	PFHZZ	0EJ14	10999	.GEAR,SPUR UOC:H04	3
53	PAHZZ	21594	95-04-117-01	.PLATE,RETAINING,SHA UOC:H04	3
54	PAHZZ	0EJ14	1397	.WASHER,LOCK UOC:H04	3
55	PAHZZ	0EJ14	1300	.SCREW,CAP,HEXAGON H UOC:H04	3
56	PFHZZ	0EJ14	10745	.SHAFT,GEAR,PLANET UOC:H04	3
57	PFHZZ	0EJ14	11367	.SHAFT,SHOULDERED UOC:H04	1
58	PFHZZ	58864	11146	.SUPPORT,GEAR END,WI UOC:H04	1
59	PAHZZ	0EJ14	11372	.BEARING,SLEEVE UOC:H04	4
60	PAHZZ	08162	416888	.SEAL UOC:H04	2
61	XDHZZ	58864	11365	.DRUM,MOTOR HYDRAULI UOC:H04	1
62	PAHZZ	0EJ14	11369	.KEY,MACHINE UOC:H04	2
63	PAHZZ	0EJ14	1379	.WASHER,LOCK UOC:H04	2
64	PAHZZ	96906	MS16997-102	.SCREW,CAP,SOCKET HE UOC:H04	2
65	PFHZZ	0EJ14	11366	.SUPPORT,MOTOR WINCH UOC:H04	1
66	PFFZZ	0EJ14	11052	.COUPLING,SHAFT,RIGI UOC:H04	1
67	PAFZZ	96906	MS16562-147	.PIN,SPRING UOC:H04	1
68	PAFZZ	0EJ14	76144	.PLUG UOC:H04	2
69	PAFZZ	0EJ14	76511	.ELBOW,PIPE UOC:H04	1
70	PAFZZ	58864	11345	.PLUG UOC:H04	1
71	XDFZZ	58864	76503	.SWIVEL JOINT,PIPE UOC:H04	1
72	PAFZZ	58864	9950	.PACKING,PREFORMED UOC:H04	1
73	PAFZZ	58864	1349	.SCREW,CAP,HEXAGON H UOC:H04	4
74	PAFZZ	58864	1384	.SCREW,CAP,HEXAGON H UOC:H04	4
75	PAFZZ	0EJ14	1388	.WASHER,LOCK UOC:H04	4
76	PAFZZ	58864	9818	.PACKING,PREFORMED UOC:H04	1

SECTION II

TM 9-2320-279-24P

(1) ITEM NO	(2) SMR CODE	(3) CAGEC	(4) PART NUMBER	(5) DESCRIPTION AND USABLE ON CODES(UOC)	(6) QTY
77	PPFZZ	58864	11344	.CONNECTOR,FLUID,PUM UOC:H04	1
78	PAFZZ	58864	9993	.PACKING,PREFORMED UOC:H04	2
79	PAFZZ	80204	B1821BH050C150N	.SCREW,CAP,HEXAGON H UOC:H04	8
80	PAFZZ	58864	1498	.WASHER,FLAT UOC:H04	4
81	PAFZZ	58864	11263	.GASKET UOC:H04	1
82	PAFZZ	0EJ14	1495	.WASHER,LOCK UOC:H04	4
83	PAFZZ	58864	76044	.PACKING,PREFORMED UOC:H04	1
84	PAFZZ	58864	1390	.NUT,PLAIN,HEXAGON UOC:H04	4
85	PAFZZ	0EJ14	1394	.WASHER,FLAT UOC:H04	4
86	XDFZZ	96906	MS51967-23	.NUT,PLAIN,HEXAGON UOC:H04	17
87	PAFZZ	0EJ14	1605	.SCREW,CAP,HEXAGON H UOC:H04	17
88	PPFZZ	58864	11354	.BRACKET,ANGLE UOC:H04	1
89	XDFZZ	58864	11353	.FRAME,WINCH UOC:H04	1
90	PAFZZ	0EJ14	1695	.WASHER,LOCK UOC:H04	17
91	PAFZZ	58864	1475	.SCREW,SHOULDER UOC:H04	4

END OF FIGURE